



F-Series Plus Cylinders

Single and Double acting

9/16" to 4" bore



Technical Data:

Medium:

Filtered, lubricated or non-lubricated, compressed air

Operating Pressure

200 psig (13.6 Bar) Max.

Temperature Range:

Standard Nitrile seals:

-40°F to 200°F (-40°C to 65°C)

150°F max. with Bumper Option

High Temp seals:

-20°F to 400°F (-29°C to 205°C)

¹With dew point of supply air less than air temperature below 35°F (2°C).

Lubrication:

All F-Series Plus cylinders are prelubricated at the time of assembly with a Teflon® based grease, for non-lube service and long life.

Side Loading:

Cylinders are specifically designed to push and pull. Side loading and misalignment of the piston rod should be avoided to ensure maximum operating performance and life.

Materials:

Cylinder Body:

304 Stainless Steel

Head and Cap:

Clear Anodized Aluminum Alloy

Piston Rod:

303 Stainless Steel

Rod Bearing:

Oil Impregnated Bronze

Piston:

Aluminum Alloy

Rod & Piston seals:

Buna-N

Options selector

FP 106 x 2.375 - PTM - PS

Series	Substitute
Single Rod end	FP
Double Rod end	FPD
Spring Extend	FPC
Spring Retract	FPR

Bore	Substitute
9/16"	056
3/4"	075
1-1/16"	106
1-1/2"	150
2"	200
2-1/2"	250
3"	300
4"	400

Stroke	Substitute
Increments of 1/8"	

Mounting Options	Substitute
*Screw Clearance Holes Front	SCF
*Screw Clearance Holes Rear	SCR
*Screw Clearance Holes Both ends	SCB
Basic Model (std. c'bored mtg. holes)	BAM
**Front Trunnion	TMF
**Rear Trunnion	TMR
**Trunnion both ends	TMB
Pivot Mount	PTM
Threaded mounting holes Front	THF
Threaded mounting holes Rear	THC
Threaded mounting holes Both ends	THB
***Nose Mount	NMT

* Screw clearance to allow bolt head to pass through - no counter bores

** Not available on 9/16" bore

*** Available in FP, FPC, and FPR. Includes a heavy duty end cap and rod wiper.

Options	Substitute
Bumper both ends (not avail. with HT) ¹	UB
Bumper Head (not avail. with HT) ¹	UH
Bumper Cap (not avail. with HT) ¹	UC
Non-Standard Female Thread*	FT()
Heavy Duty Rear End Cap ²	HD
Alternate Port Location	PL()
Low Friction Seals ²	LF
Magnetic Piston ²	PS
Switch Rail and Position (switches ordered separately) M1, M2, M3, M4	
No Rod Thread	PR
Non-Standard Male Thread	TM()
Thread Extension over standard (specify additional length) ³	TX()
Rod Extension over standard (specify additional length) ³	RX()
Stainless Steel Fasteners (125 PSI Max)	SF
High Temperature Seals ⁴	**HT
Rod Wiper	RW

¹ Stroke is reduced by .03" per bumper.

Bumpers are rated to 150°F

² Overall length of cylinder may increase with this option.

³ Consult factory for negative thread or rod extensions.

⁴ Not available in single or reverse acting models.

* Not available in 9/16" bore.

F-Series Plus Cylinders

Single and Double acting

9/16" to 4" bore

Quality and durability in a compact, high performance cylinder!

The **Norgren F-Series Plus** offers a compact design using the highest quality components for dependable service and long life. All components of the F-Series Plus cylinder have been specifically selected to provide optimum reliability and performance.

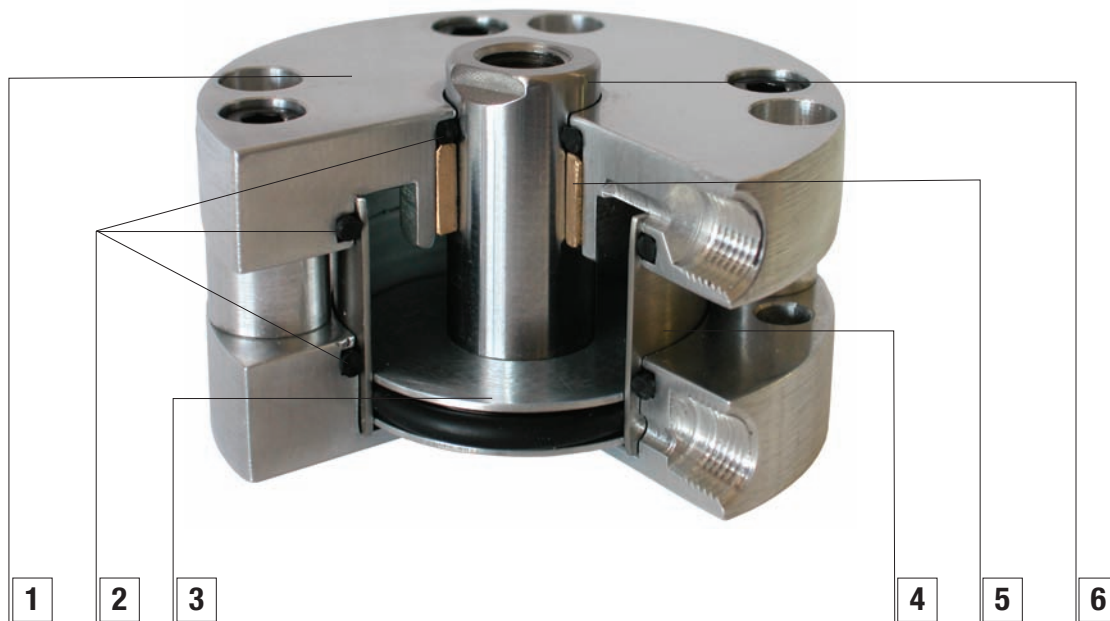

- 1** Head/Cap:
Aluminum alloy, clear anodized for corrosion resistance.
- 2** Seals:
Buna N, o-ring seals throughout
- 3** Piston:
Aluminum alloy piston is lightweight, yet strong with excellent wear characteristics.
- 4** Tube:
304 Stainless steel tube, polished and buffed I.D.
- 5** Rod Bearing:
Oil impregnated, bronze bearing, for long cylinder life and non-lube service.
- 6** Piston Rod:
303 Stainless steel, chrome plated for smooth finish and long seal life.



F-Series Plus Cylinders

Single and Double acting

9/16" to 4" bore

Option Combination Availability Chart																
✓ = Available as an option X = Not Available																
	FT()	HD	HT	LF	M1,M2, M3,M4	PL()	PR	PS	RW	RX()	SF	TM()	TX()	UB	UC	UH
FT()	✓	✓	✓	✓	✓	✓	X	✓	✓	✓	✓	X	X	✓	✓	✓
HD	✓	✓	✓	✓	✓	✓	✓	✓	✓	✓	✓	✓	✓	✓	✓	✓
HT	✓	✓	✓	✓	✓	✓	✓	✓	✓	✓	✓	✓	✓	X	X	X
LF	✓	✓	✓	✓	✓	✓	✓	✓	X	✓	✓	✓	✓	✓	✓	✓
M1,M2, M3,M4	✓	✓	✓	✓	✓	✓	✓	✓	✓	✓	✓	✓	✓	✓	✓	✓
PL()	✓	✓	✓	✓	✓	✓	✓	✓	✓	✓	✓	✓	✓	✓	✓	✓
PR	X	✓	✓	✓	✓	✓	✓	✓	✓	✓	✓	X	X	✓	✓	✓
PS	✓	✓	✓	✓	✓	✓	✓	✓	✓	✓	✓	✓	✓	✓	✓	✓
RW	✓	✓	✓	X	✓	✓	✓	✓	✓	✓	✓	✓	✓	✓	✓	✓
RX()	✓	✓	✓	✓	✓	✓	✓	✓	✓	✓	✓	✓	✓	✓	✓	✓
SF	✓	✓	✓	✓	✓	✓	✓	✓	✓	✓	✓	✓	✓	✓	✓	✓
TM()	X	✓	✓	✓	✓	✓	X	✓	✓	✓	✓	✓	✓	✓	✓	✓
TX()	X	✓	✓	✓	✓	✓	X	✓	✓	✓	✓	✓	✓	✓	✓	✓
UB	✓	✓	X	✓	✓	✓	✓	✓	✓	✓	✓	✓	✓	✓	X	X
UC	✓	✓	X	✓	✓	✓	✓	✓	✓	✓	✓	✓	✓	X	✓	X
UH	✓	✓	X	✓	✓	✓	✓	✓	✓	✓	✓	✓	✓	X	X	✓

Force Factor Data

Bore	Code	Force Factor (Area)	
		Extend	Retract
9/16"	(056)	0.25	0.20
3/4"	(075)	0.44	0.36
1-1/16"	(106)	0.89	0.69
1-1/2"	(150)	1.77	1.46
2"	(200)	3.14	2.70
2-1/2"	(250)	4.91	4.47
3"	(300)	7.07	6.47
4"	(400)	12.56	11.77

Force Output Formula

Cylinder Output Force = Force Factor (area) x Air Line Pressure (psi)

Ex: 1-1/16 bore cylinder operating at 80 psi:

Force exerted on the extend: 0.89 x 80 = 71.2 lbs.

Force exerted on the retract: 0.69 x 80 = 55.2 lbs.

Approximate Cylinder Weights (lbs.)

Bore	Code	FP		FPD		FPR, FPC		Nose Mount Option Adder to Base Weight
		Base	Adder per 1/8" stroke	Base	Adder per 1/8" stroke	Base	Adder per 1/8" stroke	
9/16"	(056)	0.075	0.005	0.081	0.009	0.094	0.005	0.006
3/4"	(075)	0.119	0.006	0.131	0.013	0.138	0.006	0.013
1-1/16"	(106)	0.306	0.019	0.363	0.025	0.331	0.019	0.069
1-1/2"	(150)	0.600	0.025	0.700	0.038	0.669	0.025	0.113
2"	(200)	0.813	0.031	0.950	0.044	0.894	0.031	0.169
2-1/2"	(250)	1.400	0.038	1.750	0.050	1.581	0.038	0.194
3"	(300)	1.806	0.050	2.375	0.069	2.050	0.050	0.219
4"	(400)	3.481	0.063	4.488	0.081	3.881	0.063	0.369

ACTUATORS

F-Series Plus Cylinders

Single and Double acting

9/16" to 4" bore

Dimensions in inches

FP (basic model BAM)
Double acting, single rod end

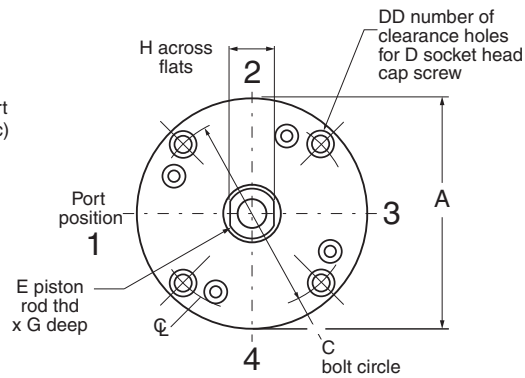
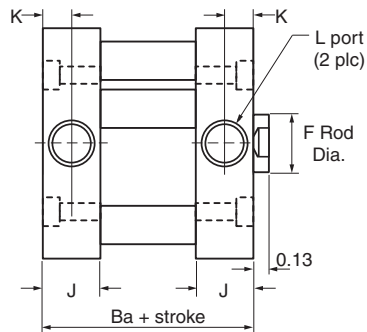

FPD (basic model BAM)
Double acting, double rod end

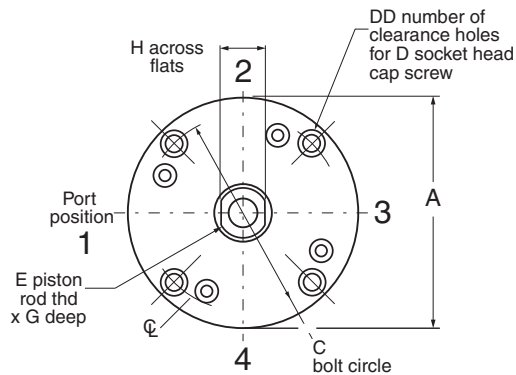
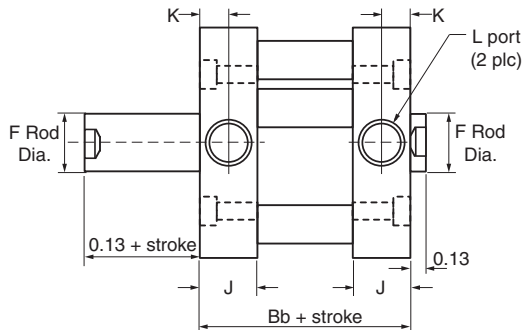

FP - Double acting, single rod end
FPD - Double acting, double rod end

Bore	Code	A	Ba* (FP)	Bb* (FPD)	C	DD	D	E Thread	G depth	F	H	J	K	L
9/16"	(056)	1.12	0.56	0.69	0.88	2	#4	8-32 UNC	.46	.25	.22	.34	.14	10-32 UNF
3/4"	(075)	1.50	0.56	0.69	1.22	4	#6	10-32 UNC	.46	.31	.25	.34	.14	10-32 UNF
1-1/16"	(106)	2.00	0.88	0.94	1.69	4	#6	5/16-24 UNF	.70	.50	.44	.50	.25	1/8 NPT
1-1/2"	(150)	2.62	0.88	1.00	2.19	4	#10	3/8-24 UNF	.70	.63	.50	.50	.25	1/8 NPT
2"	(200)	3.12	0.95	1.06	2.69	4	#10	1/2-20 UNF	.70	.75	.63	.53	.25	1/8 NPT
2-1/2"	(250)	3.75	1.19	1.31	3.25	4	1/4	1/2-20 UNF	.70	.75	.63	.66	.33	1/4 NPT
3"	(300)	4.25	1.25	1.38	3.78	4	1/4	5/8-18 UNF	.73	.88	.75	.69	.33	1/4 NPT
4"	(400)	5.50	1.56	1.69	4.94	4	5/16	3/4-16 UNF	.80	1.00	.88	.84	.42	3/8 NPT

* Length may increase with certain option combinations.



F-Series Plus Cylinders

Single and Double acting

9/16" to 4" bore

Dimensions in inches

FPR (basic model BAM)
Single acting, spring return

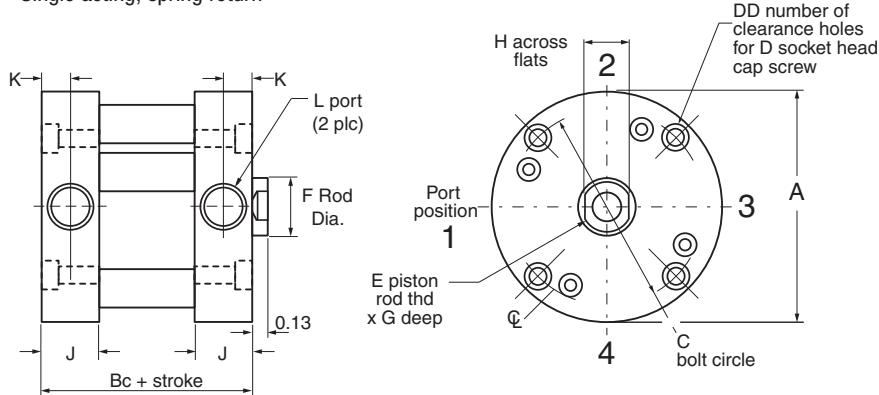

FPC (basic model BAM)
Single acting, spring extend

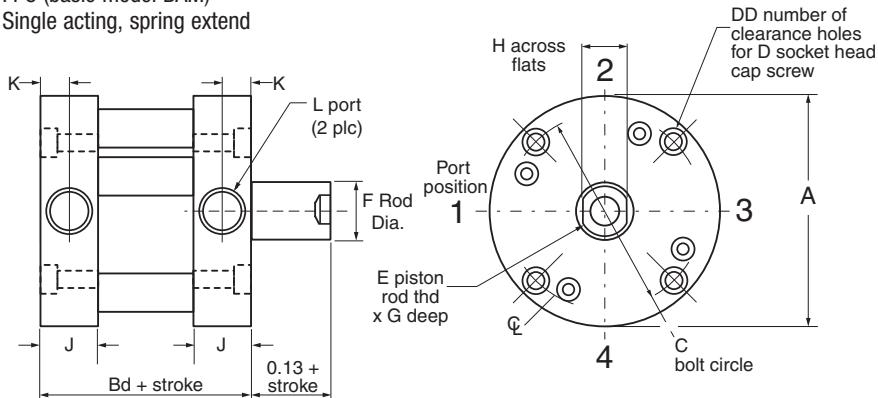

FPR - Single acting, spring return
FPC - Single acting, spring extend

Bore	Code	A	Bc* (FPR)				Bd* (FPC)				C	DD	D	E Thread	G depth	F	H	J	K	L
			0-1" Stk.	1.001-2" Stk.	2.001-3 Stk.	3.001-4" Stk.	0-1" Stk.	1.001-2" Stk.	2.001-3" Stk.	3.001-4" Stk.										
9/16"	(056)	1.12	0.81	1.38	1.96	2.52	1.06	1.62	2.14	2.70	0.88	2	#4	8-32 UNC	.46	.25	.22	.34	.14	10-32 UNF
3/4"	(075)	1.50	0.81	1.38	1.94	2.50	1.06	1.62	2.19	2.75	1.22	4	#6	10-32 UNC	.46	.31	.25	.34	.14	10-32 UNF
1-1/16"	(106)	2.00	0.88	1.50	2.13	2.75	1.38	2.00	2.63	3.25	1.69	4	#6	5/16-24 UNF	.70	.50	.44	.50	.25	1/8 NPT
1-1/2"	(150)	2.62	0.88	1.50	2.13	2.75	1.38	2.00	2.63	3.25	2.19	4	#10	3/8-24 UNF	.70	.63	.50	.50	.25	1/8 NPT
2"	(200)	3.12	0.94	1.56	2.19	2.81	1.44	2.06	2.69	N/A	2.69	4	#10	1/2-20 UNF	.70	.75	.63	.53	.25	1/8 NPT
2-1/2"	(250)	3.75	1.19	2.06	2.94	3.81	1.94	2.81	2.81	N/A	3.25	4	1/4	1/2-20 UNF	.70	.75	.63	.66	.33	1/4 NPT
3"	(300)	4.25	1.25	2.12	3.00	3.88	2.00	2.88	2.88	N/A	3.78	4	1/4	5/8-18 UNF	.73	.88	.75	.69	.33	1/4 NPT
4"	(400)	5.50	1.56	2.44	3.31	4.19	2.31	3.19	3.19	N/A	4.94	4	5/16	3/4-16 UNF	.80	1.00	.88	.84	.42	3/8 NPT

* Length may increase with certain option combinations.

F-Series Plus Cylinders

Single and Double acting

9/16" to 4" bore

Dimensions in inches

Tunnion mount (TMF, TMR, TMB)

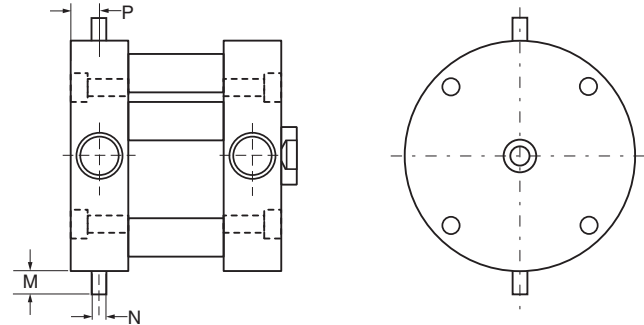
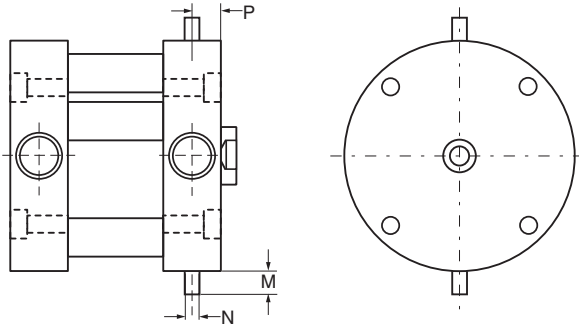

Threaded mounting holes (THF, THC, THB) 3/4" bore and larger

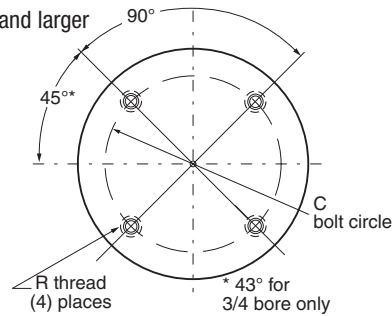
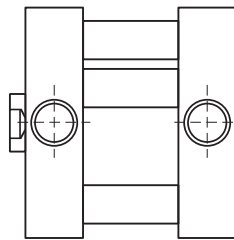

Threaded mounting holes (THF, THC, THB) 9/16" bore only

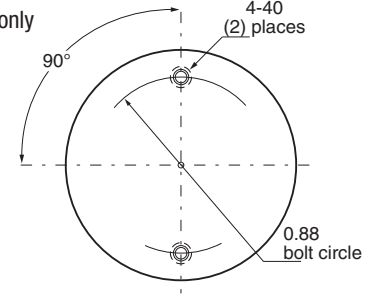
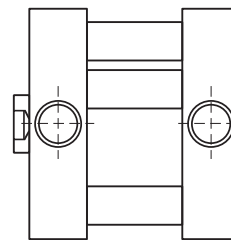

Screw clearance holes (SCF, SCR, SCB)

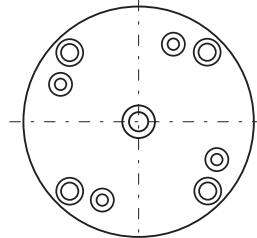
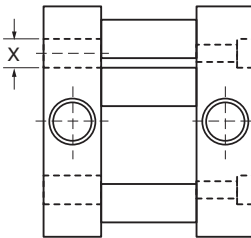

Pivot mount (PTM)

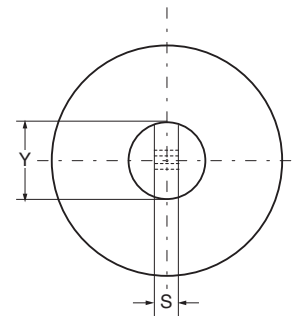
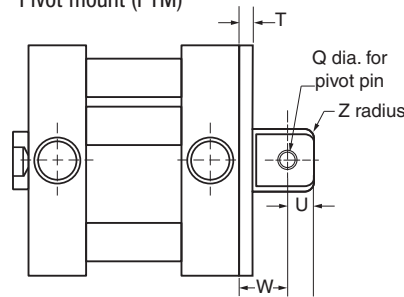

Nose mount (NMT)

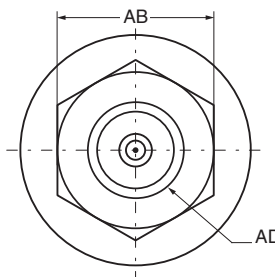
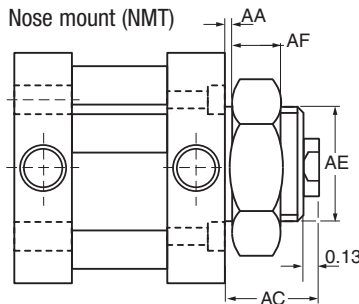

Nose Mount Maximum Torque Recommendation		
Bore	Code	Maximum Torque(ft.-lb.)
9/16"	(056)	12
3/4"	(075)	28
1-1/16"	(106)	100
1-1/2"	(150)	120
2"	(200)	130
2-1/2"	(250)	130
3"	(300)	130
4"	(400)	150

Mounting Dimensions (in)

Bore	Code	AA	AB	AC	AD	AE	AF	C	M	N	P	Q	R	S	T	U	W	X	Y	Z
9/16"	(056)	0.06	0.75 Hex	0.38	1/2-20 UNF-2A	0.50	0.31	0.88	N/A	N/A	N/A	0.19	#4-40 UNC	0.38	0.19	0.25	0.75	0.17	0.63	0.19
3/4"	(075)	0.06	0.75 Hex	0.38	5/8-18 UNF-2A	0.62	0.25	1.22	0.31	0.12	0.17	0.19	#6-32 UNC	0.38	0.19	0.25	0.75	0.23	0.75	0.19
1-1/16"	(106)	0.13	1.50 Hex	0.75	1-14 UNS-2A	1.00	0.55	1.69	0.50	0.25	0.25	0.19	#6-32 UNC	0.38	0.25	0.25	0.81	0.25	0.75	0.19
1-1/2"	(150)	0.13	1.88 Hex	0.75	1-1/4-12 UNF-2A	1.25	0.52	2.19	0.50	0.25	0.25	0.38	#10-24 UNC	0.75	0.25	0.44	1.19	0.34	1.38	0.38
2"	(200)	0.19	1.88 Hex	0.88	1-3/8-12 UNF-2A	1.38	0.52	2.69	0.50	0.25	0.25	0.38	#10-24 UNC	0.75	0.31	0.44	1.25	0.34	1.38	0.38
2-1/2"	(250)	0.25	1.88 Hex	1.00	1-3/8-12 UNF-2A	1.38	0.52	3.25	0.63	0.31	0.33	0.38	1/4-20 UNC	0.75	0.38	0.44	1.31	0.41	1.38	0.38
3"	(300)	0.25	1.88 Hex	1.00	1-3/8-12 UNF-2A	1.38	0.52	3.78	0.63	0.31	0.33	0.63	1/4-20 UNC	1.00	0.38	0.56	1.69	0.41	1.88	0.38
4"	(400)	0.19	2.62 Hex	1.12	1-3/4-12 UN-2A	1.75	0.88	4.94	0.75	0.38	0.42	0.63	5/16-18 UNC	1.00	0.44	0.56	1.75	0.50	1.88	0.38

F-Series Plus Cylinders

Single and Double acting

9/16" to 4" bore

Dimensions in inches

Rod Wiper (RW)

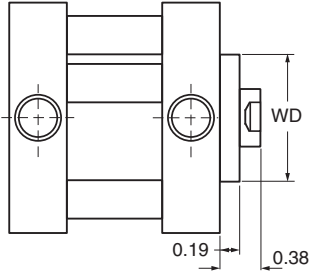

Bore	Code	WD
9/16"	(056)	0.56
3/4"	(075)	0.69
1-1/16"	(106)	0.88
1-1/2"	(150)	1.00
2"	(200)	1.13
2-1/2"	(250)	1.13
3"	(300)	1.25
4"	(400)	1.38

Male Rod End (TM(_))

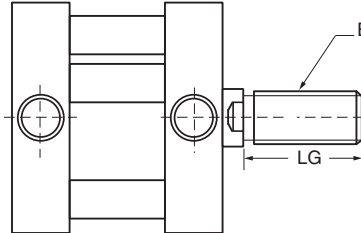

Bore	Code	E		LG
		Fine	Course	
9/16"	(056)	#8-32 UNC	N/A	0.38
3/4"	(075)	#10-32 UNF	#10-24 UNC	0.38
1-1/16"	(106)	5/16-24 UNF	5/16-18 UNC	0.50
1-1/2"	(150)	3/8-24 UNF	3/8-16 UNC	0.50
2"	(200)	1/2-20 UNF	1/2-13 UNC	0.63
2-1/2"	(250)	1/2-20 UNF	1/2-13 UNC	0.63
3"	(300)	5/8-18 UNF	5/8-11 UNC	0.75
4"	(400)	3/4-16 UNF	3/4-10 UNC	0.75

Spring Forces

Bore	Code	Maximum Force (lbs.)	Spring Rates			
			0.12 to 1" Stroke (lb/in)	1.001 to 2" Stroke (lb/in)	2.001 to 3" Stroke (lb/in)	3.001 to 4" Stroke (lb/in)
9/16"	(056)	5.25	4.25	1.75	1.24	0.88
3/4"	(075)	10.00	6.00	2.50	1.76	1.25
1-1/16"	(106)	11.50	6.00	2.50	1.76	1.25
1-1/2"	(150)	13.00	5.50	2.25	1.60	1.13
2"	(200)	13.00	5.50	2.25	1.60	1.13
2-1/2"	(250)	25.00	6.50	2.75	1.93	1.38
3"	(300)	25.00	6.50	2.75	1.93	1.38
4"	(400)	25.00	6.50	2.75	1.93	1.38

Overall length adders for options

Bore	Code	Length Adder (Add to standard cataloged length)				
		LF*	HD**	PS (Magnetic Piston)		
		(Low Friction Seals)	(Heavy Duty Cap)	FP, FPD	FPR	FPC
9/16"	(056)	0.25	0.13	0.88	0.63	0.38
3/4"	(075)	0.25	0.13	0.88	0.88	0.88
1-1/16"	(106)	0.38	0.19	0.88	0.88	0.88
1-1/2"	(150)	0.38	0.19	0.88	0.88	0.88
2"	(200)	0.38	0.19	0.88	0.88	0.88
2-1/2"	(250)	0.38	0.25	0.88	0.88	0.88
3"	(300)	0.50	0.25	0.88	0.88	0.88
4"	(400)	0.50	0.38	0.88	0.88	0.88

*For Low Friction Seals used in combination with a magnetic piston, use the PS length adder only.

**For Heavy Duty End Cap used in combination with a magnetic piston, use both HD and PS length adders.

F-Series Plus Cylinders

Single and Double acting

9/16" to 4" bore

Dimensions in inches

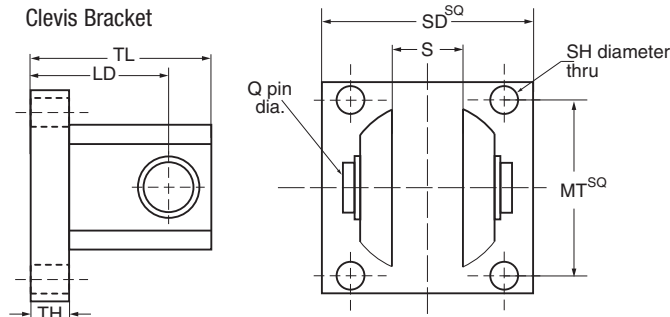

Bore	Code	Part Number	LD	MT	Q	S	SH	SD	TH	TL
9/16"	(056)	FCB-1	0.56	0.75	0.19	0.39	#6	1.00	0.16	0.78
3/4"	(075)									
1-1/16"	(106)									
1-1/2"	(150)	FCB-2	0.94	1.38	0.38	0.75	#10	1.75	0.22	1.34
2"	(200)									
2-1/2"	(250)									
3"	(300)	FCB-3	1.25	2.00	0.63	1.00	0.25	2.50	0.25	1.81
4"	(400)									

Trunnion Block Mount

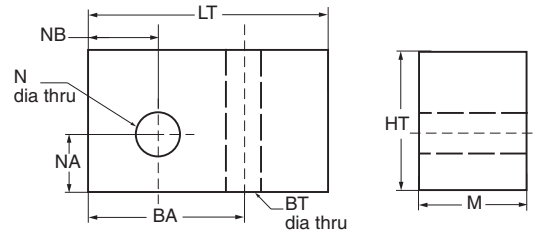

Bore	Code	Part Number	BA	BT	HT	LT	M	N	NA	NB
3/4"	(075)	FTB-1	0.56	#10	0.63	1.12	0.31	0.13	0.30	0.22
1-1/16"	(106)	FTB-2	0.81	0.25	0.88	1.50	0.50	0.25	0.38	0.31
1-1/2"	(150)									
2"	(200)	FTB-3	0.94	0.31	1.00	1.63	0.63	0.31	0.45	0.38
2-1/2"	(250)									
3"	(300)	FTB-4	1.06	0.38	1.25	1.88	0.75	0.38	0.55	0.44
4"	(400)									

Rod Clevis

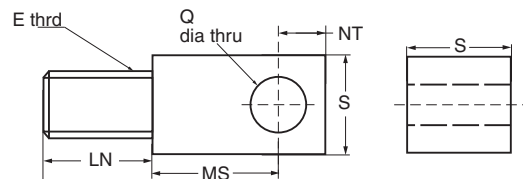

Bore	Code	Part Number	E	LN	MS	NT	Q	S
9/16"	(056)	FRE-1	#8-32 UNC	0.38	0.47	0.25	0.19	0.38
3/4"	(075)	FRE-2	#10-32 UNF	0.38	0.47	0.25	0.19	0.38
1-1/16"	(106)	FRE-3	5/16-24 UNF	0.63	0.47	0.25	0.19	0.38
1-1/2"	(150)	FRE-4	3/8-24 UNF	0.63	0.75	0.44	0.38	0.75
2"	(200)	FRE-5	1/2-20 UNF	0.75	0.75	0.44	0.38	0.75
2-1/2"	(250)	FRE-6	5/8-18 UNF	0.88	1.00	0.63	0.63	1.00
3"	(300)							
4"	(400)	FRE-7	3/4-16 UNF	0.88	1.00	0.63	0.63	1.00